

---

## Isolation Dampers



## TABLE OF CONTENTS

<b>Quality Assurance</b> .....	<b>4</b>
<b>Round Bubble-Tight Isolation Dampers</b> .....	<b>5</b>
Ordering Information.....	6
Suggested Specifications .....	7
<b>Individual Square Bubble-Tight Isolation Dampers</b> .....	<b>6</b>
Bolt Hole Patterns.....	8
Ordering Information.....	10
Performance Chart .....	10
<b>Individual or Multi-Dish Dampers for Larger Airflows</b> .....	<b>11</b>
Bolt Hole Patterns.....	11
Ordering Information.....	12
Suggested Specifications .....	13
<b>Typical Applications</b>	
Bubble-Tight, Dish Type and Flat Blade.....	14

# Quality Assurance Program

AAF Flanders established the Quality Assurance program to address the 18 criteria structure of ASME NQA-1 (formally N45.2), "Quality Assurance Requirements for Nuclear Facility Applications." As suppliers of High Efficiency Air Filtration products and services, there are three standards that govern the majority of AAF Flanders' activities.

1. ASME N509-1989 (reaffirmed 1996)  
"Nuclear Power Plant Air-cleaning Units and Components"
2. ASME N510-1989 (reaffirmed 1995)  
"Testing of Nuclear Air Treatment Systems"
3. ASME AG-1- latest revision  
"Code on Nuclear Air and Gas Treatment"

These standards and our customer's specifications invoke many other standards and codes the AAF Flanders' Quality Assurance program incorporates as standard practice.

There are a variety of Quality Assurance programs that manufacturers implement to ensure product and service quality, two such systems are ISO-9001 and ASME NQA-1.

## Abstracts of these programs include:

**ISO 9001:2015** specifies requirements for a Quality Management System where an organization

1. Needs to demonstrate its ability to consistently provide product that meets customer and applicable regulatory requirements, and
2. Aims to enhance customer satisfaction through the effective application of the system, including processes for continual improvement of the system, and the assurance of conformity to customer and applicable regulatory requirements.

All requirements of this international standard are generic and are intended to be applicable to all organizations, regardless of type, size, and product provided.<sup>1</sup>

## ASME NQA-1:

This Standard sets forth requirements for the establishment and execution of quality assurance programs for the siting, design, construction, operation, and decommissioning of nuclear facilities. Non-mandatory guidance is provided in the Appendices. NQA-1 establishes 18 criteria covering all aspects of quality, from purchase of raw materials to design and testing.<sup>2</sup>

Because ASME NQA-1 applies to the Nuclear Industry where containment and safety are of paramount concern, it is generally seen to establish more checks and balances.

Containment air filtration started out as a critical requirement in the Nuclear industry to protect workers, the public, and the environment. Today, containment air filtration is a critical issue in a variety of industries and applications, from pharmaceutical, health care, military, and the original nuclear applications among others. Because of the critical safety requirements of the nuclear industry, ASME N509, ASME N510, and ASME AG-1 are recognized as the standards for design and testing of containment air filtration systems. Each of these standards requires a Quality Assurance program that meets the requirements of ASME NQA-1.

AAF Flanders is certified to ISO 9001:2015 and maintains a full scope Quality Assurance program that meets the requirements of ASME NQA-1, 10 CFR 50 Appendix B, and DOE O 414 1A. Customers that require the stringent application of quality principles that only a mature and developed program can offer routinely audit this Quality Assurance program.

## Sources:

1. [ISO.org](http://ISO.org)
2. [ASME.org](http://ASME.org)
3. *Comparison NQA 1 and ISO 9001 Technical Report, available from ASME.org*

# Bubble-Tight Isolation Dampers: Introduction

AAF Flanders manufactures isolation dampers for effective shut-off and isolation of one or more tiers of filters in a hazardous-duty containment exhaust system. The bubble-tight isolation dampers are AAF Flanders top-of-the-line dampers. They are used for isolation of a filter or filter bank primarily during the filter change-out process. AAF Flanders isolation dampers are especially designed to provide cost-effective isolation of filter banks with high volumes of air.

In a biohazard environment, the dampers enable the air filtration system to be shut off for decontamination and/or filter changing.

A variety of sizes and configurations are available for a wide range of air flows. These dampers are available in round, square, and rectangular shaped housings, making them adaptable to most applications.

AAF Flanders round isolation damper is designed for sealing off and/or controlling airflow in round ducts and pipes. AAF Flanders square isolation damper is designed for use as a single damper in ductwork. Rectangular dampers are grouped in multiple configurations to form a damper bank for any size housing configuration. AAF Flanders guarantees a bubble-tight seal at a differential pressure of ten (10) inches water gage as specified in ASME N509.

## **Custom Designs**

In addition to the standard designs, many special requirements may be satisfied through options or through custom design. Our engineering and manufacturing personnel have extensive experience in the production of equipment and filters for containment filtration systems. They will assist you in designing and specifying a configuration that exactly meets your requirements.

The AAF Flanders reputation for excellence in the design and fabrication of critical air filtration systems is the result of decades of attention to the toughest environmental and safety standards in the world. Throughout the long development of our containment housings, isolation dampers, and in-place test sections, safety has been the first design priority, and our track record reflects the confidence of our customers.

AAF Flanders systems are operating in hundreds of sites, including:

- Hospital Isolation Suites
- Pharmaceutical Facilities
- Microelectronic Sites
- Food Processing Areas
- Genetic and Biotech Labs
- University Campuses
- Industrial Process Exhaust Systems
- Chemical Process Facilities
- Animal Disease Laboratories
- Radioisotope Handling Facilities
- Nuclear Power Plants
- Strategic Nuclear Facilities
- HVAC Systems
- Department of Energy Facilities
- Military Facilities
- Biohazard Facilities

# Round Bubble-Tight Isolation Dampers (Flat Blade Type)

## Round Bubble-Tight Isolation Dampers

Round bubble-tight dampers are designed to function as both isolation dampers and control dampers. For isolation purposes, the round bubble-tight damper is used for isolation of a filter bank primarily during the filter change-out process. These dampers are bolted (recommended option) or seal-welded on the end of an air flow transition. As a control damper, it is used to regulate the flow of air through the filter system. However, they are *not* designed for modulating service.

AAF Flanders flat blade round isolation damper has been tested over 45,000 open/close cycles. This number of cycles could represent more than 100 years of field operation. The damper leakage test result was bubble-tight at ten (10) inches water gage after the cycle testing.

A variety of sizes and configurations are available for a wide range of air flows. Round bubble-tight dampers are furnished with cylindrical housings only, but connecting flanges can change in size and/or shape.

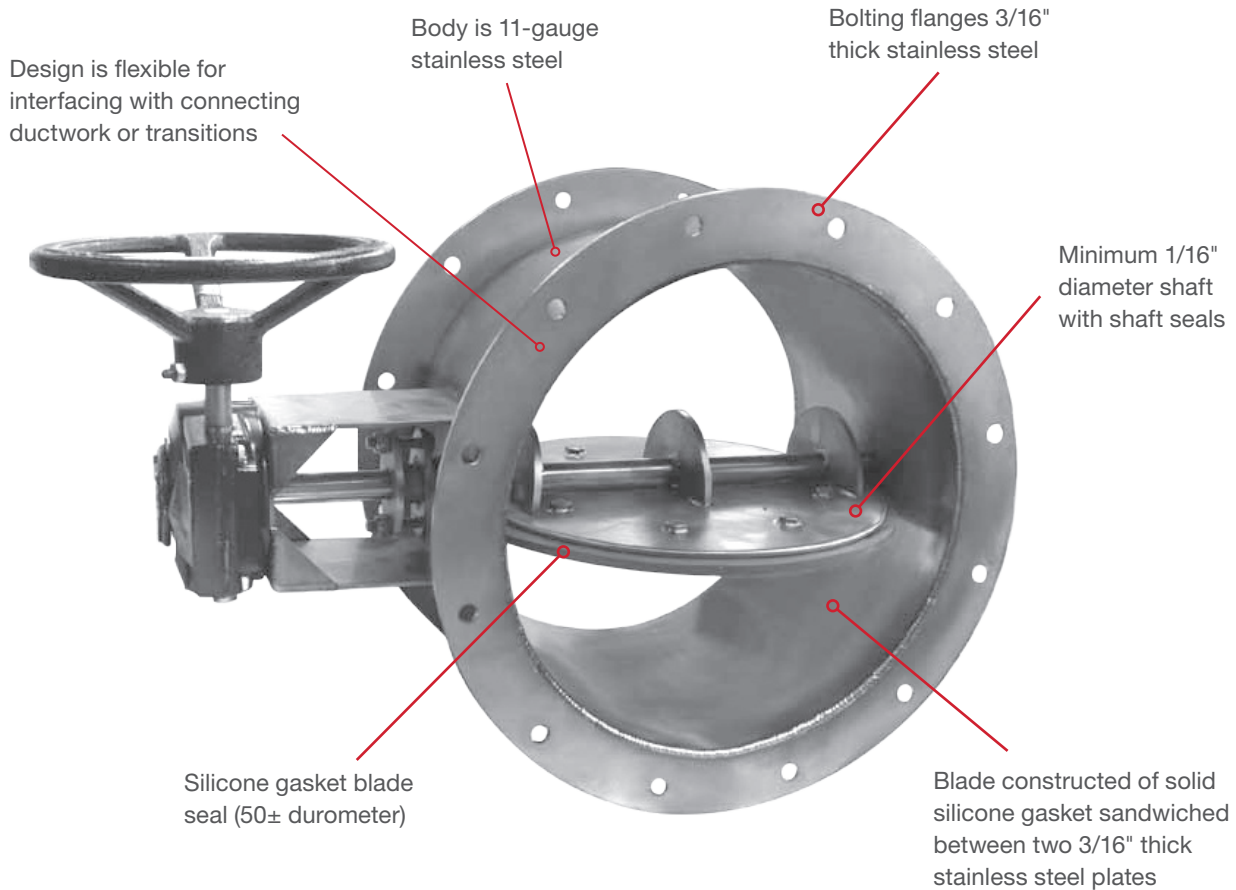

# Round Bubble-Tight Isolation Dampers (Flat Blade Type): Ordering Information

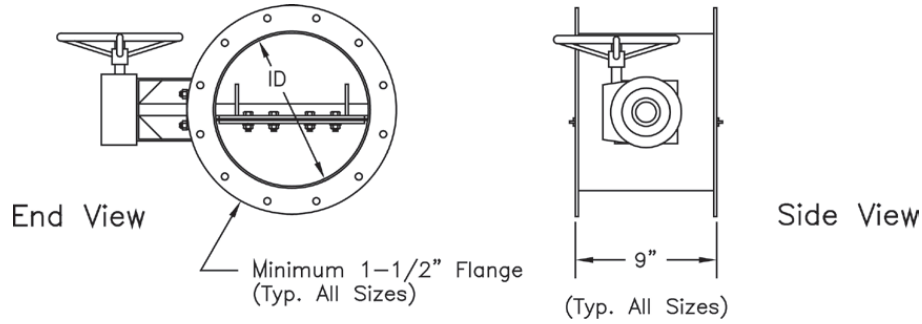

## Model Number Breakdown (Example)

**Damper Series**  
DTB = Damper  
Bubble Tight

**Blade**  
FB = Flat Blade

### Housing Construction Material

304 = Type 304 Stainless Steel (Standard)  
304L = Type 304L Stainless Steel  
316L = Type 316L Stainless Steel

# DBT\* - FB - 304 - 18

### Actuator Options

M = Manual  
P = Pneumatic  
E = Electric

### Damper Size

See Schedule Below

Model No. (See Note 1)	ID	Dia. of Bolt Circle	No. of Bolt Holes
DBT*-FB-304-6	5-3/4"	8-1/16"	8
DBT*-FB-304-8	7-3/4"	10-1/16"	8
DBT*-FB-304-10	9-3/4"	12-1/16"	12
DBT*-FB-304-12	11-3/4"	14-1/16"	12
DBT*-FB-304-14	13-3/4"	16-1/16"	16
DBT*-FB-304-16	15-3/4"	18-1/16"	16
DBT*-FB-304-18	17-3/4"	20-1/16"	16
DBT*-FB-304-20	19-3/4"	22-1/16"	20
DBT*-FB-304-22	21-3/4"	24-1/16"	20
DBT*-FB-304-24	23-3/4"	26-1/16"	24

Model No. (See Note 1)	ID	Dia. of Bolt Circle	No. of Bolt Holes
DBT*-FB-304-26	25-3/4"	28-1/16"	24
DBT*-FB-304-28	27-3/4"	30-1/16"	24
DBT*-FB-304-30	29-3/4"	32-1/16"	28
DBT*-FB-304-32	31-3/4"	34-1/16"	28
DBT*-FB-304-34	33-3/4"	36-1/16"	32
DBT*-FB-304-36	35-3/4"	38-1/16"	32
DBT*-FB-304-38	37-3/4"	40-1/16"	34
DBT*-FB-304-40	39-3/4"	42-1/16"	36
DBT*-FB-304-42	41-3/4"	44-1/16"	36
DBT*-FB-304-44	43-3/4"	46-1/16"	38

### \* Type of Actuator

M=Manual  
E=Electric  
P=Pneumatic

- Notes:**
1. Refer to complete model number code above.
  2. Dimensions shown in schedule are AAF Flanders standard. AAF Flanders can manufacture dampers to custom fit any existing round ductwork.
  3. Static pressure through open dampers is negligible with reasonable velocities.

# Round Bubble-Tight Isolation Dampers (Flat Blade Type)

## Suggested Specifications

The standard construction for model number \_\_\_\_\_ (insert appropriate model number) shall be as follows. Flanges shall be minimum 1-1/2" wide by 3/16" thick. Factory-drilled holes (7/16" diameter) shall be no more than four (4) inches apart as recommended in DOE-HDBK-1169-2003. Nuclear Air Cleaning Handbook, chapter 4, 4-23. The frame material shall be minimum 11-gauge unpainted Type 304 stainless steel. All linkage components shall be manufactured from 300-series stainless steel. Shafts are minimum 3/4" diameter stainless steel rod with shaft seals.

The dampers shall be positive seal, isolation type that shall be bubble-tight at the differential pressure of ten (10) inches water gage (for higher design pressures, contact the factory). The blade shall consist of two (2) 3/16" thick type 304 stainless steel plates with a replaceable solid silicone gasket between them. Blade seal shall occur when the gasket seats against the inside of the 11-gauge housing wall. The damper shall be all-weld design. All "Pressure Retaining" weld joints and seams shall be continuously welded with no pores allowed. Weld joints and seams requiring only intermittent welds, such as reinforcement members, shall not be continuously welded. As a minimum, all-weld joints and seams shall be wire-brushed and/or buffed to remove heat discoloration, burrs, and sharp edges.

The dampers shall be manufactured under a quality assurance program that meets all the requirements of ASME NQA-1, "Quality Assurance Program Requirements for Nuclear Facilities." All welding procedures, welders, and welder operators shall be qualified in accordance with ASME Boiler and Pressure Vessel Code, Section IX. All production welds shall be visually inspected per the AAF Flanders Standard Work Instruction WI-03-022, "Visual Inspection of Welds," which incorporates the workmanship acceptance criteria described in Sections 5 and 6 of ANSI/AWS D9.1-1990, "Specifications for Welding Sheet Metal."

The damper blade shall be tested in the closed position at 10" water gage and shall be bubbletight when tested in accordance with ASME N509- 1996 "Reaffirmed" paragraph 5.9.7.3. The complete pressure boundary (damper housing) shall be leak tested by the "Pressure Decay Method" in accordance with ASME N510-1995 "Reaffirmed," "Testing of Nuclear Air Treatment Systems," Paragraphs 6 and 7. Pressure readings are recorded once a minute until pressure decays to 75% of the test pressure or for 5 minutes. There shall be a maximum leak rate of 0.0005 CFM per cubic foot of housing volume at (10) inches water gage.

### Actuators:

Manual (M): Manual actuators shall be 1/4-turn worm geared actuator with handwheel. Actuator has aluminum base and cover. Rated output torque shall be 2,000-inch pounds up to 22-inch diameter size dampers with a gear ration of 30:1 (7,000 inch pounds on dampers 24" to 44" diameter size, with a gear ration of 40:1). Actuator shall be fully lubricated and self locking to hold at any position, and equipped with a visual indicator to show the damper position.

### Options:

- Beacon indicators with end travel limit switches.
- Digital damper position transmitter.

### Electric (E):

Electric rotary actuator shall have rugged, high-torque, integral motor and shall be equipped with factory-set travel limit switches. The actuator shall also be equipped with motor brake. Specific models and options for various output torque and speed are available. Customer to specify desired options, speed, voltage, and phase.

### Options:

- Beacon indicators with end travel limit switches.
- Manual handwheel override.
- Digital damper position transmitter.
- Fail-safe spring return.

### Pneumatic (P):

Pneumatic actuator shall be rotary type with flow control valves (i.e., cushions). Customer to specify desired options and available air pressure.

### Options:

- Beacon indicators with end travel limit switches.
- Manual handwheel override.
- Pneumatic and electric-operated solenoid/control valves.
- Digital damper position transmitter.
- Standard operating pressure is 80 psi. (other pressures available).
- Fail-safe spring return.

# Square Bubble-Tight Isolation Dampers (Dish Type)

## Individual Bubble-Tight Isolation Dampers

This design accommodates lower air flows using a single dish damper in a square housing. These dampers are designed to mate directly to transitions. Dampers may be bolted (recommended option) or seal-welded to match the flange configuration. Square single dish dampers are only offered with 12-, 16-, and 18-inch dishes.

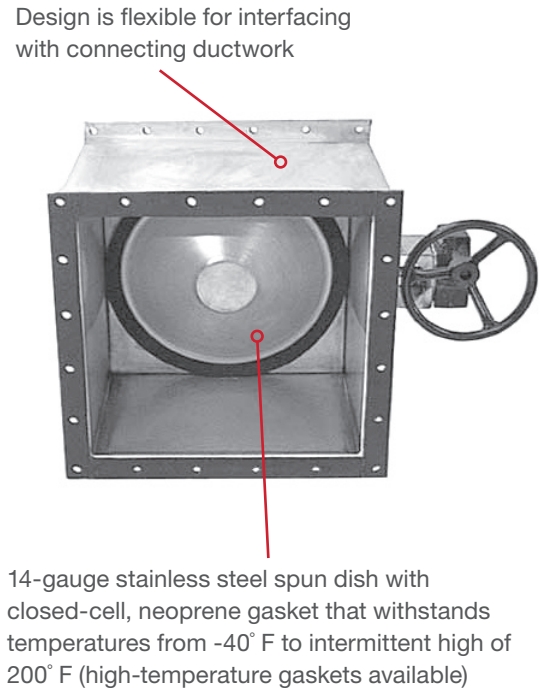
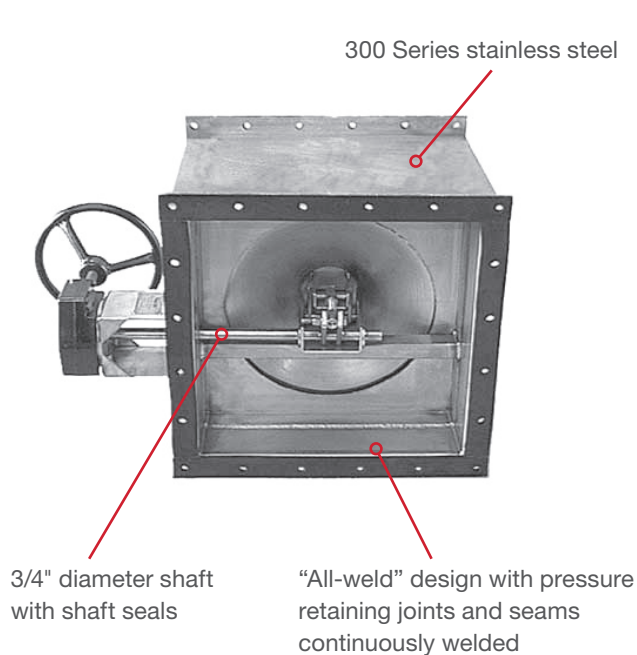

All AAF Flanders isolation dampers are furnished with factory-drilled bolt holes in duct connection flanges to facilitate replacement if required. Bolt hole spacing is in accordance with the recommendation found in chapter 4, 4-23 of the Nuclear Air Cleaning Handbook, "DOE-HDBK-1169-2003". (A maximum bolt spacing of four (4) inches is recommended for flanges). Schedule shown is for the three standard square single blade sizes.

Damper Size	Dimension A	Dimension B
12	3-11/32"	8-1/16"
16	3-29/64"	10-1/16"
18	3-51/64"	12-1/16"

Isolation Damper Bolt Hole Patterns

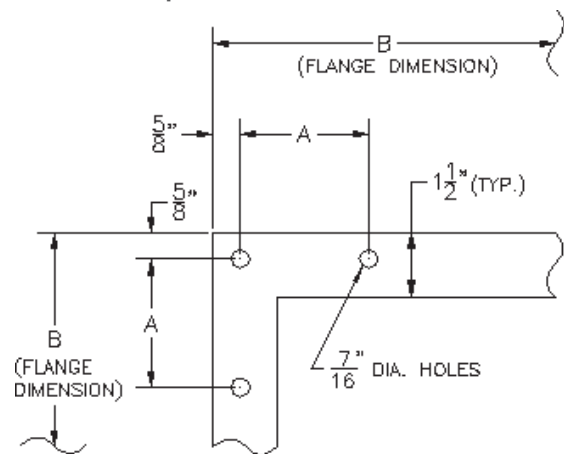



# Square Bubble-Tight Isolation Dampers (Dish Type)

## Standard Square Damper Housings Dimensions

### Selection of Damper Size

The square bubble-tight dampers (dish type) are offered in three standard sizes. Nominal dish sizes are 12", 16", and 18" diameters. Size refers to the actual dimension of the opening the dish covers when sealing, not the diameter of the dish. It is important when selecting damper size to achieve optimum velocity and pressure drop within the limits of space, air flow, and interface with connecting duct work. (See Performance Data Chart on page 10.)

**Notes:** All bolt holes 7/16" diameter

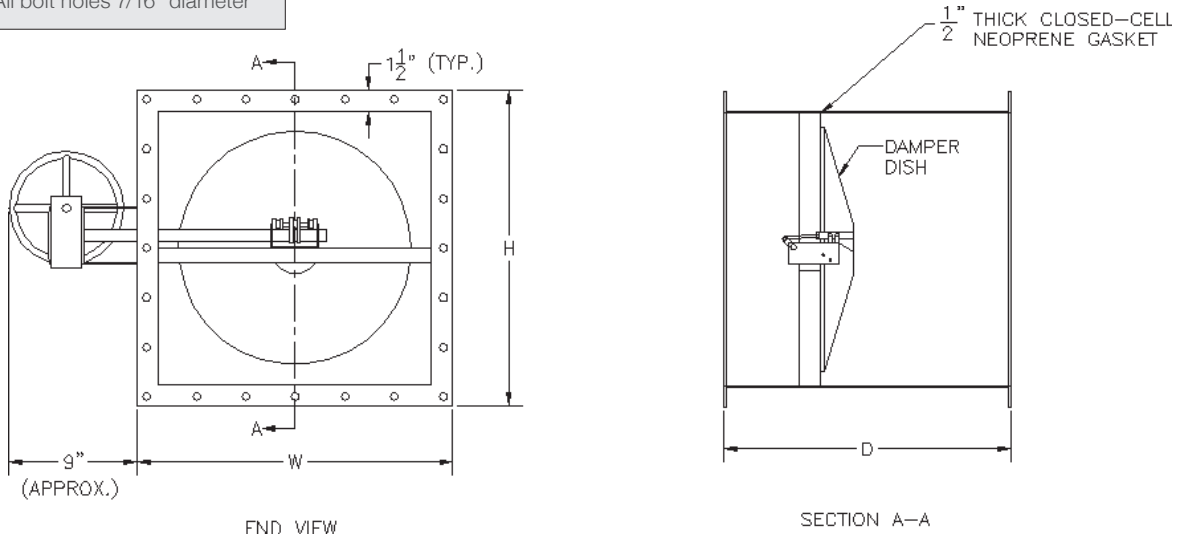

### Standard Square Damper Housing Dimensions for Single Dish Dampers

Model Number (See Note 1)	Height (H) (See Note 2)	Width (W) (See Note 2)	Depth (D) (See Note 3)
DBT*-1H1W-304-12	18"	18"	16"
DBT*-1H1W-304-16	18"	22"	20"
DBT*-1H1W-304-18	24"	24"	20"

- Notes:**
1. Refer to complete model number code on page 10.
  2. Height and width dimensions shown are standard, but flange may be extended to allow dampers to mount directly to existing duct work.
  3. Damper frame is designed to prevent the damper dish from extending beyond the bolting flange. If dimension is critical, then the frame can be modified to allow the dish to open into duct or plenum.

# Square Bubble-Tight Isolation Dampers (Dish Type)

## Ordering Information

### Model Number Breakdown (Example)

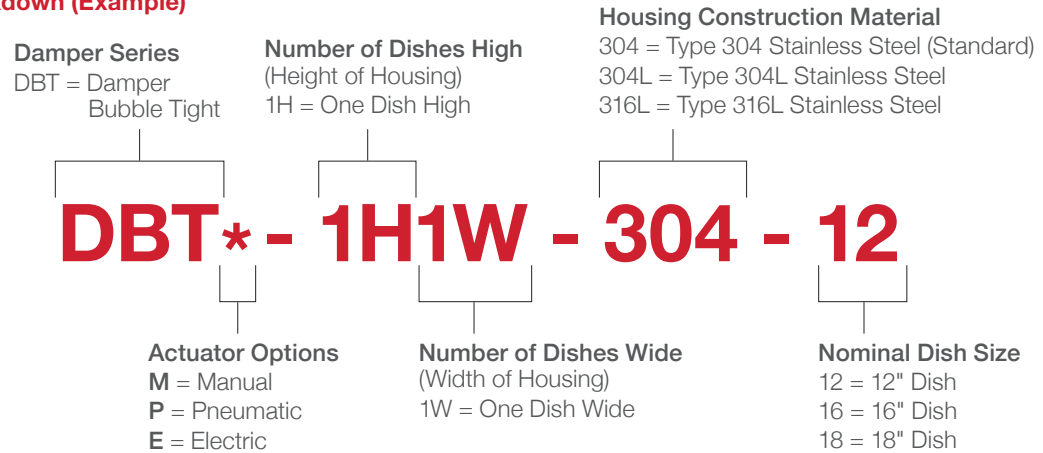

### Performance Chart

Damper Face Velocity (FPM) and Pressure Drop (Inches Water Gage) at flow rates shown below:

Damper Model Number	Dia. of Damper Opening	Adjusted Area** of Opening (FT <sup>2</sup> )	800 CFM		1000 CFM		1200 CFM		1500 CFM	
			Velocity (FPM)	Δ P in W.G.	Velocity (FPM)	Δ P in W.G.	Velocity (FPM)	Δ P in W.G.	Velocity (FPM)	Δ P in W.G.
DBT*-1H1W-304-12	12-1/4"	0.635	1260	0.03	1575	0.06	1890	0.08	---	---
DBT*-1H1W-304-16	16-1/4"	1.246	642	0.015	803	0.03	963	0.04	1204	0.68
DBT*-1H1W-304-18	18-1/4"	1.617	495	0.02	618	0.03	742	0.05	928	0.07
DBT*-1H1W-GG-304-20	20-1/4"	2.032	394	0.011	492	0.018	590	0.025	738	0.042

Damper Model Number	Dia. of Damper Opening	Adjusted Area** of Opening (FT <sup>2</sup> )	2000 CFM		2500 CFM		3000 CFM		4000 CFM	
			Velocity (FPM)	Δ P in W.G.	Velocity (FPM)	Δ P in W.G.	Velocity (FPM)	Δ P in W.G.	Velocity (FPM)	Δ P in W.G.
DBT*-1H1W-304-12	12-1/4"	0.635	---	---	---	---	---	---	---	---
DBT*-1H1W-304-16	16-1/4"	1.246	1605	0.122	---	---	---	---	---	---
DBT*-1H1W-304-18	18-1/4"	1.617	1237	0.094	1546	0.147	1855	0.212	---	---
DBT*-1H1W-GG-304-20	20-1/4"	2.032	984394	0.075	1230	0.117	1476	0.168	1968	0.299

**Notes:** Dark-gray shaded area indicates recommended sizes.

\* Type of Actuator

\*\* Area of damper opening minus total area of components

# Rectangle Bubble-Tight Isolation Dampers (Dish Type)

## Ordering Information

### Individual or Multi-Dish Dampers for Larger Air Flow

Rectangular bubble-tight dampers are designed to bolt directly (or be welded) to standard size AAF Flanders containment filter housings or in-place test housings. This allows for the isolation of tiers on larger systems and eliminates the need for transitions between dampers and housing. These dampers are configured to match single housings or multiple-height or -width housings. (See size chart page 12.)

**Note:** Multi-high dampers require more than one actuator.



3H3W Multi-Dish Damper Unit Shown in Closed Position  
Shown with Manual Actuators

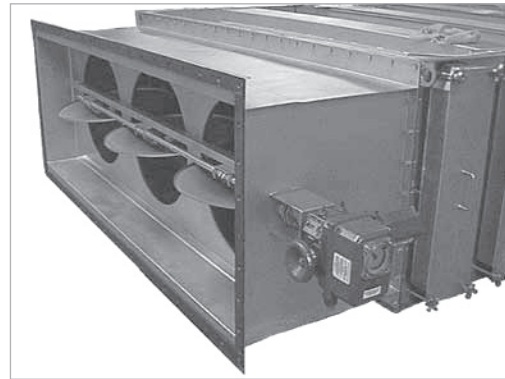

1H3W Multi-Dish Damper Unit Shown in Open Position  
Shown with Electric Actuators

### Model Number Breakdown (Example)

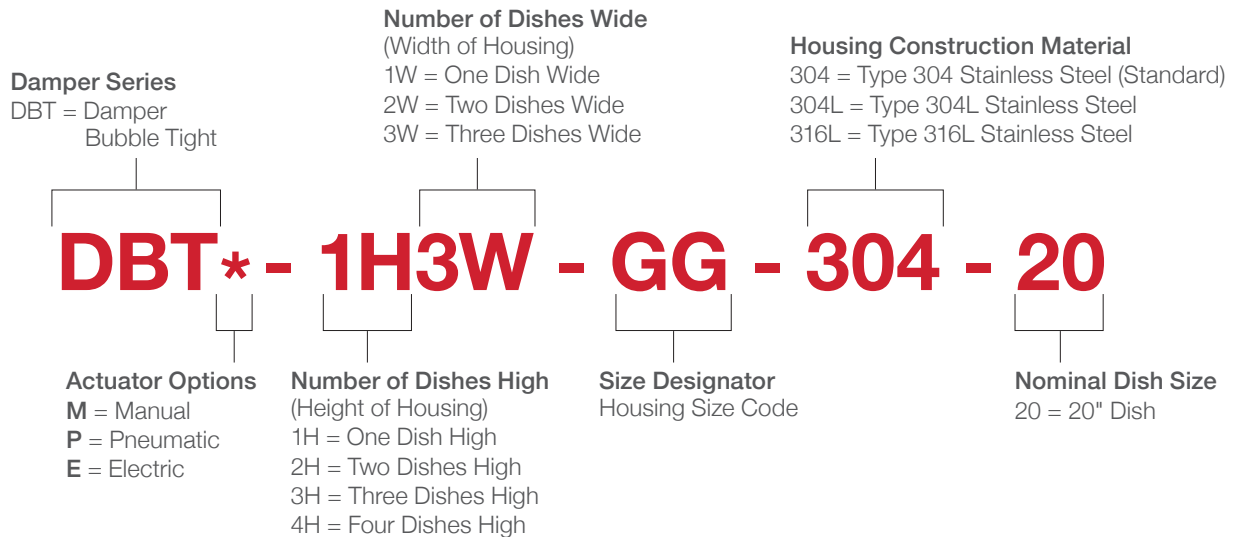

# Rectangle Bubble-Tight Isolation Dampers (Dish Type)

## Bubble-Tight Isolation Damper Size Chart

Model Number (See Note 1)	Height (H) (See Note 2)	Width (W) (See Note 2)	Depth (D) (See Note 3)
DBT*-1H1W-GG-304-20	30"	27"	22"
DBT*-1H2W-GG-304-20	30"	51"	22"
DBT*-1H3W-GG-304-20	30"	75"	22"

- Notes:**
1. Refer to complete model number code on page 11.
  2. Height and width dimensions shown are standard, but flange may be extended to allow dampers to mount directly to existing duct work.
  3. Damper frame is designed to prevent the damper dish from extending beyond the bolting flange. If dimension is critical, then the frame can be modified to allow the dish to open into duct or plenum.

## Drilled Duct Connection Flanges

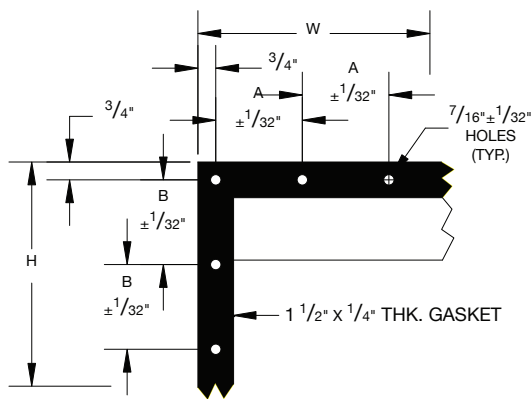

Standard Bolt Hole Pattern			
Housing Size	1H1W	1H2W	1H3W
W Width	27"	51"	75"
A Horizontal Spaces	3-41/64"	3-13/16"	3-43/64"
No. of Spaces (A) Between Corer Holes	7	13	20
H Height	30"	30"	30"
B Vertical Spaces	3-9/16"	3-9/16"	3-9/16"
No. of Spaces (B) Between Corer Holes	8	8	8

## Multi-High Bolt Hole Patterns

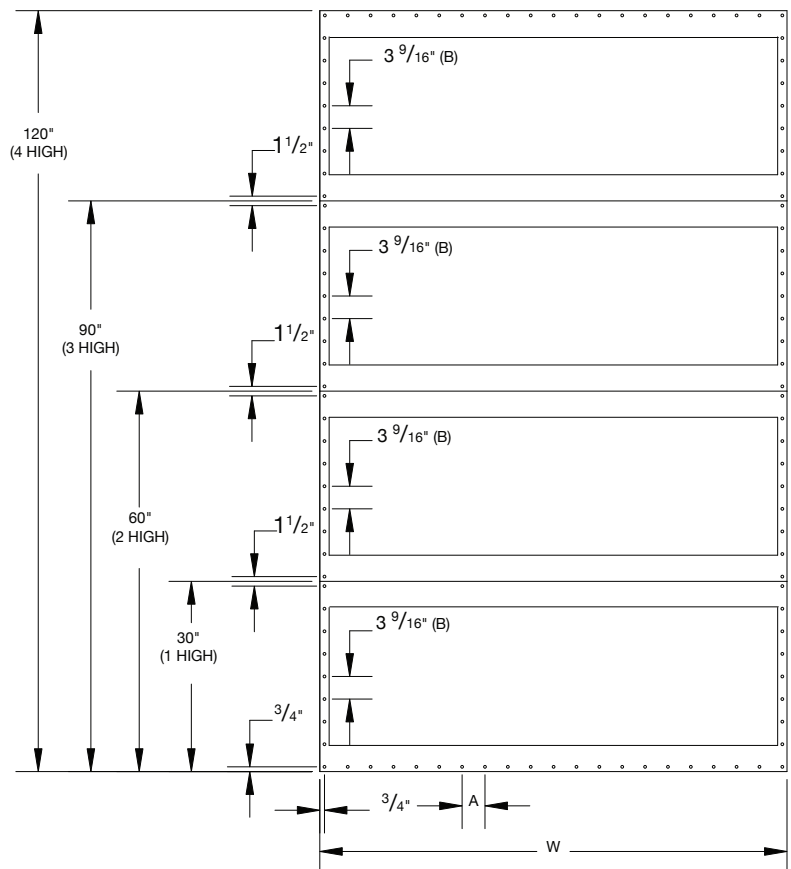

- Notes:** Multiple-high or -wide units will have bolt hole patterns made up of 1 high x 1, 2, or 3 wide patterns.

# Bubble-Tight Isolation Dampers (Dish Type)

## Suggested Specifications

The standard construction for model number \_\_\_\_\_ (insert appropriate model number) shall be as follows. Flanges shall be minimum 1-1/2" wide. Factory-drilled holes (7/16" diameter) shall be no more than four (4) inches apart as recommended in DOEHDBK-1169-2003. Nuclear Air Cleaning Handbook, chapter 4, 4-23. The frame material shall be 11- and 14-gauge unpainted type 304 stainless steel. All linkage components shall be manufactured from 300 series stainless steel. Shafts are minimum 3/4" diameter stainless steel rod with shaft seals.

The dampers shall be positive seal, isolation type that shall be bubble-tight at a differential pressure of ten (10) inches water gage (for higher design pressures, contact the factory). Dampers shall be constructed with a 11-gauge type 304 stainless steel dish-shaped blade with a knife edge that seats against a type 304 stainless steel frame. The frame shall have a closed-cell neoprene rubber gasket that creates a gasket-to-knife edge seal. The damper shall be all-weld design. All "pressure retaining" weld joints and seams shall be continuously welded with no pores allowed. Weld joints and seams requiring only intermittent welds, such as reinforcement members, shall not be continuously welded. At minimum, all weld joints and seams shall be wire-brushed and/or buffed to remove heat discoloration, burrs, and sharp edges.

The dampers shall be manufactured under a quality assurance program that meets all the requirements of ASME NQA-1, "Quality Assurance Program Requirements for Nuclear Facilities." All welding procedures, welders, and welder operators shall be qualified in accordance with ASME Boiler and Pressure Vessel Code, Section IX. All production welds shall be visually inspected per the AAF Flanders Standard Work Instruction WI-03-022, "Visual Inspection of Welds," which incorporates the workmanship acceptance criteria described in sections 5 and 6 of ANSI/AWS D9.1-1990, "Specifications for Welding Sheet Metal."

The damper blade shall be tested in the closed position at 10" water gage and shall be bubbletight when tested in accordance with ASME N509- 1996 "Reaffirmed," paragraph 5.9.7.3. The complete pressure boundary (damper housing) shall be leak tested by the "Pressure Decay Method" in accordance Bubble-Tight Isolation Dampers (Dish Type) Suggested Specifications with ASME N510-1995 "Reaffirmed," "Testing of Nuclear Air Treatment Systems," paragraphs 6 and 7. Pressure readings are recorded once a minute until pressure decays to 75% of the test pressure or for 5 minutes. There shall be a maximum leak rate of 0.0005 CFM per cubic foot of housing volume at ten (10) inches water gage.

### Actuators:

Manual (M): Manual actuators shall be 1/4-turn worm geared actuator with handwheel. Actuator has aluminum base and cover. Rated output torque shall be 2,000 inch pounds with a gear ratio of 30:1 Actuator shall be fully lubricated and self locking to hold at any position, and equipped with a visual indicator to show the damper position.

### Options:

- Beacon indicators with end travel limit switches.
- Digital damper position transmitter.

### Electric (E):

Electric rotary actuator shall have rugged, high-torque, integral motor and shall be equipped with factory-set travel limit switches. The actuator shall also be equipped with motor brake. Specific models and options for various output torque and speed are available. Customer to specify desired options, speed, voltage, and phase.

### Options:

- Beacon indicators with end travel limit switches.
- Manual handwheel override.
- Digital damper position transmitter.
- Fail-safe spring return.

### Pneumatic (P):

Pneumatic actuator shall be rotary type with flow control valves (i.e., cushions). Customer to specify desired options and available air pressure.

### Options:

- Beacon indicators with end travel limit switches.
- Manual handwheel override.
- Pneumatic and electric-operated solenoid/control valves.
- Digital damper position transmitter.
- Standard operating pressure is 80 psi.  
(other pressures available).
- Fail-safe spring return.

# Isolation Dampers

## Leak Testing (Flat Blade and Dish Dampers)

Both the sealing surface and complete assembly pressure boundary are leak tested by the Pressure Decay Method in accordance with ASME N510-1995 reaffirmed, Testing of Air-Cleaning Systems, Paragraphs 6 and 7. Readings are recorded once a minute for five (5) minutes. AAF Flanders standard acceptable maximum leak rate is 0.0005 CM per cubic foot of housing volume at ten (10) inches water gage for the filter sealing surface, and 0.0005 CFM per cubic foot of housing column at the design pressure for the housing pressure boundary.

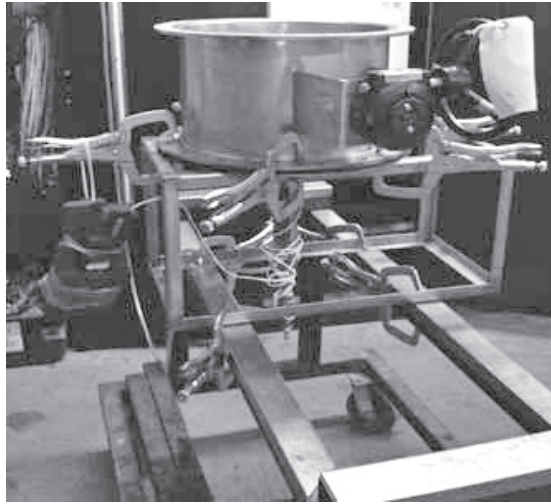
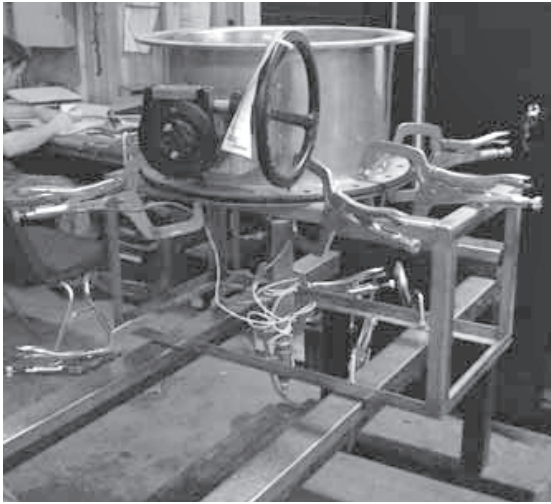

## Typical Applications

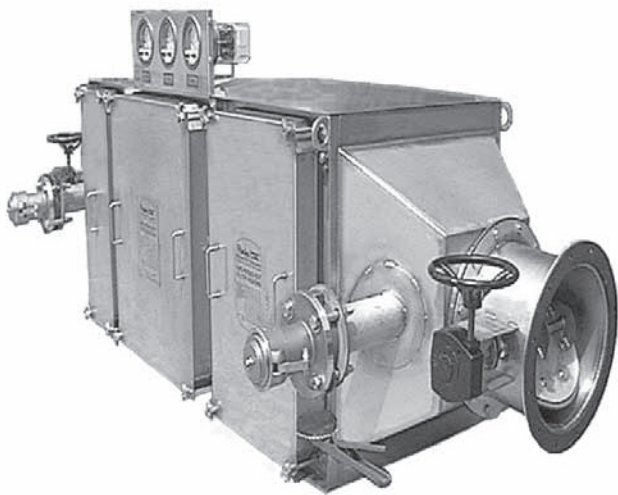

Bubble-tight flat blade isolation dampers used in a biocontainment application at a research university in New York. This design provides isolation for the decontamination process and during filter change.

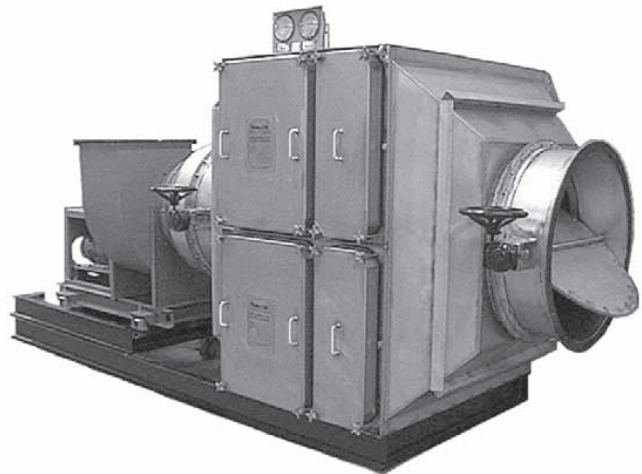

Isolation dampers, upstream and downstream, used to shut down airflow on a 4000 cfm self-contained filtration system.

# Bubble-Tight Isolation Dampers (Dish Type)

## Typical Applications

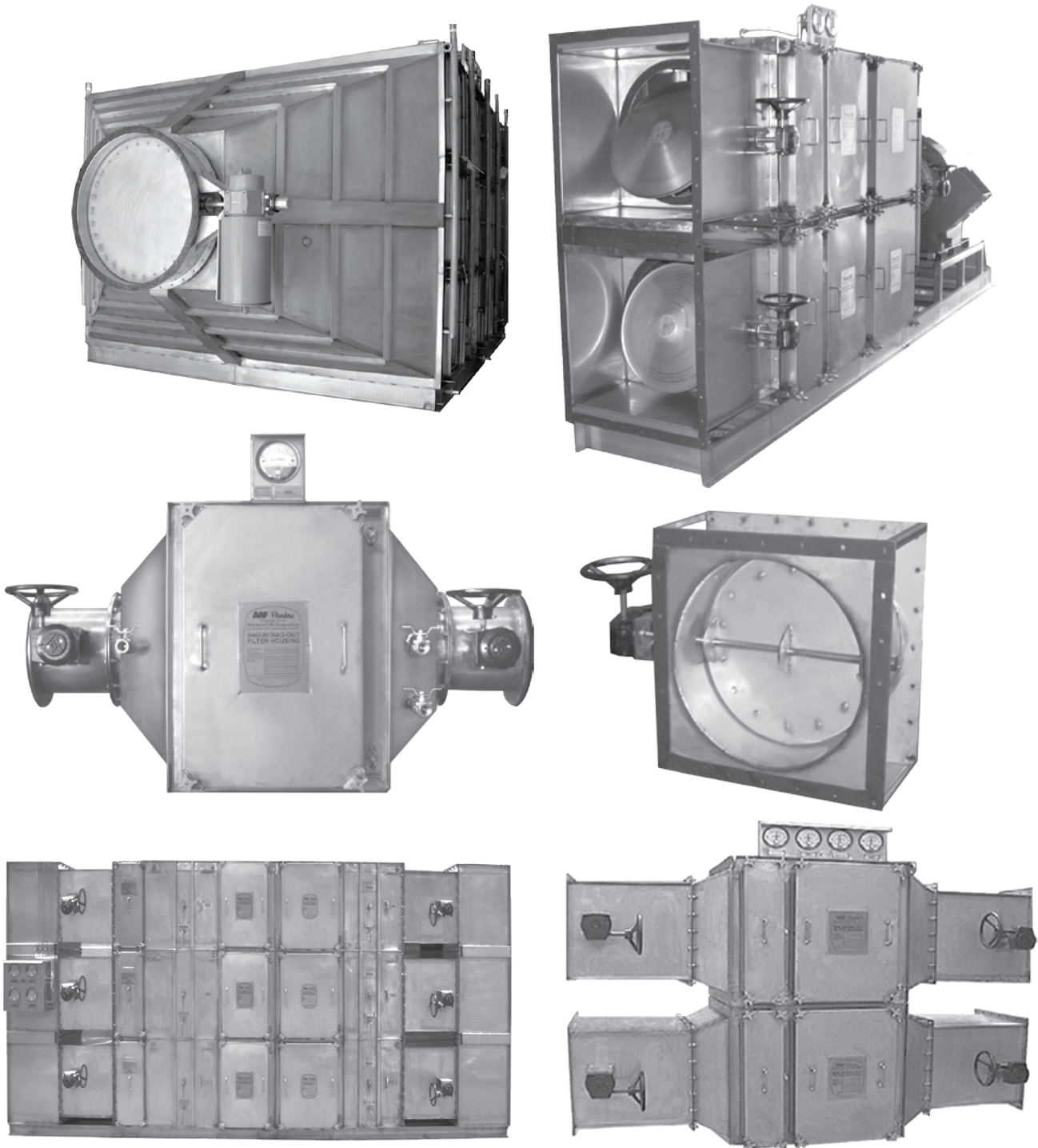

*Depictions of multiple possible configurations of dampers and actuators that can be used to isolate filtration systems.*

### **Important Notice**

For best results in the application of AAF Flanders products, it is recommended that the buyer supply complete information about the operating conditions of the ventilation system to AAF Flanders for prior evaluation.

AAF Flanders does not guarantee that its equipment will operate at the performance levels given on the identification labels, or in the catalog specifications under all conditions of installation and use, nor does AAF Flanders guarantee that suitability of its product for the particular end use that may be contemplated by the buyer. When the system components are supplied to the buyer or an agent for final installation and assembly in the field, it should be under the supervision of factory-trained personnel who are equipped to test the installation and certify its performance and conformance to industry-accepted specifications. Failure to follow these procedures may result in a compromised installation.



Bringing clean air to life.®

9920 Corporate Campus Drive, Suite 2200, Louisville, KY 40223-5690  
888.223.2003 Fax 888.223.6500 | aafintl.com

AAF Flanders has a policy of continuous product research and improvement. We reserve the right to change design and specifications without notice.

©2020 AAF International and its affiliated companies.

ISO Certified Firm

CSP-3-109A 11/20