

4 3				
99.99% EFFICIENCY on 0.3 µm				
Qty	Part Number	Size (in) (H x W x D)	Style Code	RATED CFM @ 0.75 in wg
	905-301-003	24 x 24 x 11-1/2	E24A24AA1P13T2T0BA	2000
	905-301-024	24 x 12 x 11-1/2	E24A12AA1P13T2T0BA	935
	E12A24AA1P13T2T0BA	12 x 24 x 11-1/2	E12A24AA1P13T2T0BA	935
D	E23D23DA1P13T2T0BA	23-3/8 x 23-3/8 x 11-1/2	E23D23DA1P13T2T0BA	1900
		23-3/8 x 11-3/8 x 11-1/2	E23D11DA1P13T2T0BA	850
		11-3/8 x 23-3/8 x 11-1/2	E11D23DA1P13T2T0BA	850

99.999% EFFICIENCY on 0.3 µm				
Qty	Part Number	Size (in) (H x W x D)	Style Code	RATED CFM @ 1.0 in wg
		24 x 24 x 11-1/2	E24A24AA1T15T2T0BA	2000
		24 x 12 x 11-1/2	E24A12AA1T15T2T0BA	935
		12 x 24 x 11-1/2	E12A24AA1T15T2T0BA	935
C		23-3/8 x 23-3/8 x 11-1/2	E23D23DA1T15T2T0BA	1900
		23-3/8 x 11-3/8 x 11-1/2	E23D11DA1T15T2T0BA	850
		11-3/8 x 23-3/8 x 11-1/2	E11D23DA1T15T2T0BA	850

OPTIONS		CHECK BOX
GASKET MATERIAL	URETHANE	<input type="checkbox"/>
	EPDM	<input type="checkbox"/>
GASKET LOCATION	UPSTREAM	<input type="checkbox"/>
	BOTH FACES	<input type="checkbox"/>
FACEGUARD	NONE	<input type="checkbox"/>
	UPSTREAM	<input type="checkbox"/>
	DOWNSTREAM	<input type="checkbox"/>
FRAME	BOTH FACES	<input type="checkbox"/>
	304 SS	<input type="checkbox"/>
	409 SS	<input type="checkbox"/>
	ALUMINUM	<input type="checkbox"/>

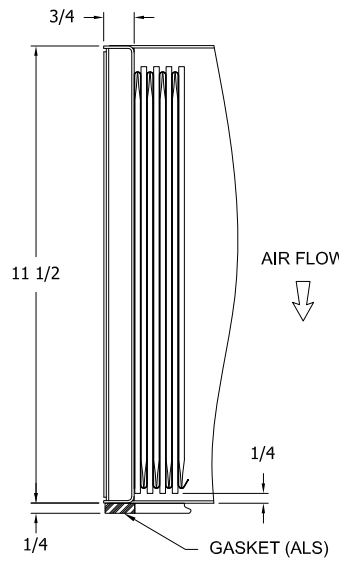
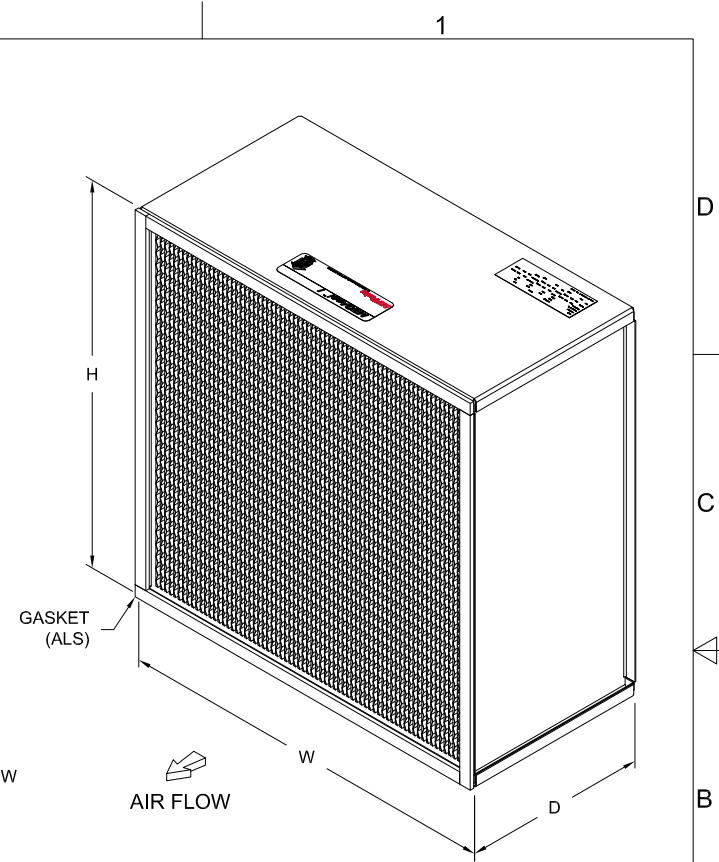

SIDE SECTION

NOTES:

FRAME - 18 GA. GALVANIZED, COLD ROLLED STEEL

TOLERANCE:

HEIGHT AND WIDTH - >12" +0, -0.125"
 ≤12" +0, -.0625"

DEPTH - +.0625, -0

DIAGONALS - <30" DIAGONALS WITHIN 0.125"
 >30" DIAGONALS WITHIN 0.250"

SEPARATORS - TAPERED CORRUGATED ALUMINUM FOIL

SEALANT - PHOSPHORUS FREE, FIRE RETARDANT POLYURETHANE

MEDIA - PAO COMPATIBLE EXPANDED POLYTETRAFLUOROETHYLENE (eFRM) MEMBRANE WITH PROTECTIVE NON WOVEN SYNTHETIC SCRIM

GASKET - 0.25" THICK X 0.75" WIDE NEOPRENE SPONGE DOWNSTREAM

CLASSIFICATION - UL-900

MAXIMUM OPERATING TEMPERATURE - 175°F

SALES/SUBMITTAL DRAWING			THIRD ANGLE PROJECTION	MODELED BY: BSH DATE: 01NOV2019 DRAWN BY: GAC DATE: 11NOV2019 CHECKED BY: CC DATE: 10NOV2019 APPROVED BY: MAR DATE: 12DEC2019	TITLE	ESTIMATED WEIGHT:	DRAWING NUMBER
APPROVAL BLOCK <input type="checkbox"/> OKAY AS IS <input type="checkbox"/> OKAY WITH REVISIONS NOTED SIGNATURE: _____ DATE: _____	<small>CONFIDENTIAL</small> ©2015 AAF INTERNATIONAL. ALL RIGHTS RESERVED. THIS DRAWING AND THE INFORMATION CONTAINED OR REFERENCED HEREIN REMAINS THE EXCLUSIVE PROPERTY OF AAF INTERNATIONAL AND IS LOANED IN STRICT CONFIDENCE WITH THE UNDERSTANDING THAT IT WILL NOT BE REPRODUCED NOR USED FOR ANY PURPOSE EXCEPT FOR WHICH IT WAS LOANED. THIS DRAWING SHALL BE IMMEDIATELY RETURNED OR DESTROYED UPON REQUEST AND IS SUBJECT TO ALL OTHER TERMS AND CONDITIONS OF ANY WRITTEN AGREEMENT OR PURCHASE ORDER TO WHICH IT RELATES.		SUBMITTAL - MEGAcel I eFRM METAL FRAME, GASKET SEAL	105	B	3172539	REV. SHEET 1 OF 1

4

3

2

1